

Emergency Stop Relay with Off-Delayed Contacts

Characteristics

- 2 instantaneous contacts:
Stop Category 0, Safety Category 4
- 3 off-delayed contacts:
Stop Category 1, Safety Category 3
- Cross-fault monitoring
- Monitored or automatic start
- Suitable for use with light curtains
- Plug-in terminal blocks

Description

Electrical sub-systems of industrial machinery must incorporate safety circuits as defined by Clause 9.4 of DIN EN 60204 (Part 1) / VDE 0113 (Part 1).

The Emergency Stop Relay **F138** fulfills these requirements in accordance with EN 954-1.

It can be used in 1- or 2-channel applications, with or without cross-fault monitoring.

The **F138** is put into operational state either by closing the external re-set contact, or by wiring the unit for automatic re-set (see wiring diagrams on the next page).

Mode of Operation

When the power supply is switched on and the emergency stop, feedback, and re-set circuits are closed, the unit is ready for operation. The ready state is indicated by the „PWR“ LED lighting up. After the re-set contact is closed, the unit's safety relays are energised and the corresponding relay status LEDs light up.

When an emergency stop circuit is opened, the relays CH1 and CH2 are de-energised immediately, the corresponding relay status LEDs are extinguished and the lapse of time begins. Following the delay-off period the relays CHT1 and CHT2 de-energise and their corresponding status LEDs extinguish. During delay timing, the delayed contacts can be caused to be opened by opening the re-set circuit across terminals Y39-Y40.

In monitored start mode, the re-set circuit is interrogated each time the unit is switched on. If the re-set contact is closed before



opening of the emergency stop contacts, or before switching on the power supply, the unit cannot enter into the „ready“ state (i.e., it cannot be re-set). In auto-start mode (terminals X1-X2 and X3-X4 shorted), the unit becomes operational immediately upon the power supply being switched on, if the emergency stop, feedback, and re-set circuits are closed.

If both emergency stop contacts are not closed simultaneously, the Channel 2 circuit must be closed before Channel 1 (e.g. in protective door monitoring applications).

If inputs are activated via external 24 V_{DC} supply, the negative potential (0 V_{DC}) must be connected to terminal S21 (Only 24V-versions, e.g., in light curtain applications with PNP output).

When an external contactor is used with the **F138**, normally-closed contacts must be connected across terminals Y1-Y2 (feedback circuit).

If no external contacts are to be monitored, or delayed re-set is not to be used, then terminals Y1-Y2 and Y39-Y40 (respectively) should be shorted.

The **F138** is equipped with plug-in screw-terminal blocks for easy installation.

Models and Ordering Data

Contacts	2 instantaneous NO contacts 3 delayed NO contacts		
F138 A	Order No.		
Delay range:	0.15 - 3s	0.5 - 10s	1.5 - 30s
230VAC	074 00188	074 00189	074 00190
115VAC	074 00191	074 00192	074 00193
42VAC	074 00194	074 00195	074 00196
24VAC/DC	074 00197	074 00198	074 00199

Versions with fixed times (>30s too) on request



* = Approval pending

Technical Data

Rated voltage	230 / 115 / 42V _{AC} ; 24V _{AC/DC}
Voltage range	0.85 to 1.1 x rated voltage
Power consumption	Approx. 4W
Rated insulation voltage	250V
Creep distance and gaps	Overtoltage Category III, Pollution level 2 to DIN VDE 0110-1(04/97)
Test voltage	2.5kV
Ambient temperature	-5°C to +50°C
Mode of protection	IP 20 / DIN VDE 0470-1
Switching capacity	250V _{AC} ; 1250VA / 24V _{DC} ; 120W, preferably with spark arrest
Thermic current I _{th}	Max. 7A in one current path
24V _{AC/DC} supply:	5 x 3.5A or 3 x 4.5A
42-230V supply:	5 x 2.5A or 3 x 3.5A
Utilisation category	AC-15 230V 6A; DC-13 24V 3A
Response time	Via reset button: < 80ms; Autostart: < 250ms
Release time at rated voltage	Via E.stop button: ≤ 15ms; loss of supply: < 100ms
Recovery time	> 0.1s after E-stop or light curtain Operation, > 1s after loss of supply > 3 s before monitored reset
Output contacts	2 N/O (instant safety contacts) 3 N/C (delayed safety contacts)
Mechanical lifetime	10 ⁷ switching cycles
Switch material	AgSnO ₂ , 0.5μ Au
Terminals	Terminal box with wire protection
Line cross section	2.5mm ²
Control circuit	Approx. 24V _{DC}
Contact protection	Screwed-type fuse: max 6A slow blow Auto circuit breaker: max C10A
Weight	490g; Type 24V _{AC/DC} 350g

Wiring Example 1

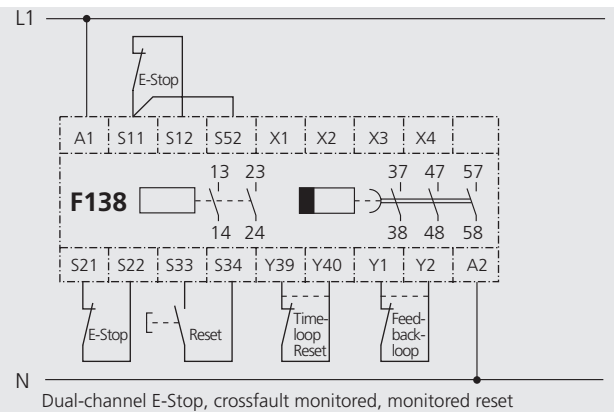

Wiring Example 2

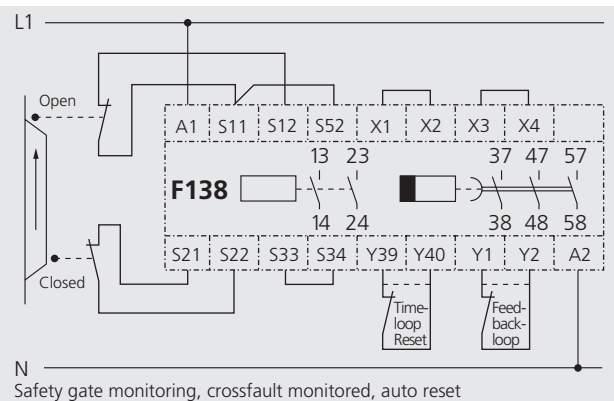

Dimensional Diagram

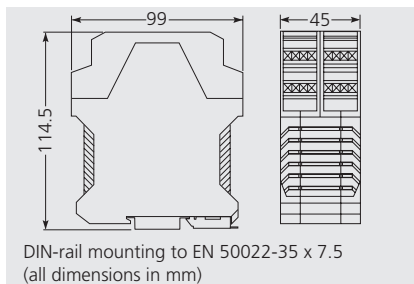

Terminal Diagram

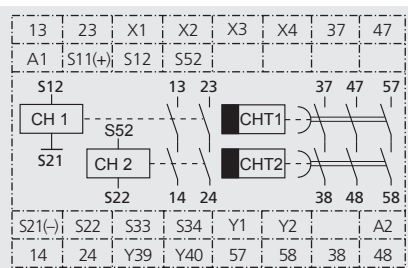

Block Diagram

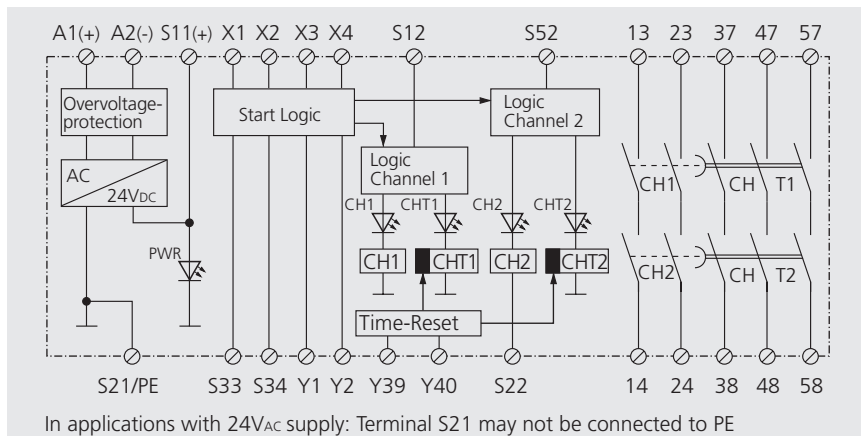

- Start contact (monitored Reset): S33 — S34
- Automatic Reset: Connections between X1 – X2, X3 – X4 and S33 – S34
- Feedback-loop (NC-contact control of external contactors): Y1 — Y2 (otherwise linked)
- Timer-Reset (undelayed de-energisation): Y39 — Y40 (otherwise linked)
- Singel Channel E-Stop: S11 — S12, Connection between S12 – S52 and S21 – S22
- PNP- Input activation: CH1: +24V to S12, CH2: +24V to S52, Connection between S21 – S22

